



TorTech

T/A TorTech Limited Partnership ABN. 31 801 764 359

TORTECH Pty Ltd & TRANSTEST Pty Ltd
4/31 Wentworth St
Greenacre NSW 2190
Po Box 194 Nth Strathfield NSW 2137
Tel: (02) 9642 6003 Fax: (02) 9642 6127
Email: general@tortech.com.au
Website: www.tortech.com.au

OWNER'S MANUAL

Installation - Operation - Maintenance

This manual is designed for

INV-300-12-S
INV-600-12-S
INV-1000-12-S



Edited with the demo version of
Infix Pro PDF Editor

To remove this notice, visit:
www.iceni.com/unlock.htm



TorTech

T/A TorTech Limited Partnership ABN. 31 801 764 359

TORTECH Pty Ltd & TRANSTEST Pty Ltd
4/31 Wentworth St
Greenacre NSW 2190
Po Box 194 Nth Strathfield NSW 2137
Tel: (02) 9642 6003 Fax: (02) 9642 6127
Email: general@tortech.com.au
Website: www.tortech.com.au

Table of Contents

1. INTRODUCTION	3
2. SAFETY INSTRUCTIONS	3
3. SPECIFICATIONS	4
4. MAIN COMPONENTS	5
5. INSTALLATION	5
6. OPERATION	8
7. TROUBLESHOOTING	9
8. MAINTENANCE	10
9. WARRANTY.....	10



TorTech

T/A TorTech Limited Partnership ABN. 31 801 764 359

TORTECH Pty Ltd & TRANSTEST Pty Ltd
4/31 Wentworth St
Greenacre NSW 2190
Po Box 194 Nth Strathfield NSW 2137
Tel: (02) 9642 6003 Fax: (02) 9642 6127
Email: general@tortech.com.au
Website: www.tortech.com.au

1. INTRODUCTION

Rite Power Pure Sine Wave series models are used in a wide range of applications including automotives, marines, solar panels, and wind turbines. It will operate TVs, VCRs, personal computers, small appliances and tools such as drills, sanders, grinders, mixers and blenders. The inverter **must** have a greater power rating than the load it is providing power to. To get the most out of the power inverter, it must be installed and used properly.

2. SAFETY INSTRUCTIONS

Please read these instructions before installing or operating the inverter to prevent personal injury or damage to the inverter.

Installation and wiring compliance

Installation and wiring must comply with the local and national electrical codes and must be done by a certified electrician.

Preventing electrical shock

- Always connect the grounding connection on the inverter to the appropriate grounding
- Disassembly / repair should be carried out by qualified personnel only
- Disconnect all AC and DC side connections before working on any circuits associated with the inverter. Turning the on/off switch on the inverter to off position may not entirely remove dangerous voltages
- Be careful when touching bare terminals of capacitors. The capacitors may retain high lethal voltages even after the power has been removed. Discharge the capacitors before working on the circuits

Preventing fire and explosion hazards

Working with the inverter may produce arcs or sparks. Thus, the inverter should not be used in areas where there are inflammable materials or gases requiring ignition protected equipment. These areas may include spaces containing gasoline powered machinery, fuel tanks, battery compartments.

Precautions when working with batteries

- Batteries contain very corrosive diluted sulfuric acid as electrolyte. Precautions should be taken to prevent contact with skin, eyes or clothing
- Batteries generate hydrogen and oxygen during charging resulting in evolution of explosive gas mixture. Care should be taken to ventilate the battery area and follow the battery manufacturer's recommendations
- Never smoke or allow a spark or flame near the batteries
- Use caution to reduce the risk of dropping a metal tool on the battery. It could spark or short circuit the battery or other electrical parts and could cause an explosion
- Remove metal items like rings, bracelets and watches when working with batteries. The batteries can produce a short circuit current high enough to weld a ring or the like to metal and thus cause a severe burn



TorTech

T/A Tortech Limited Partnership ABN. 31 801 764 359

TORTECH Pty Ltd & TRANSTEST Pty Ltd
4/31 Wentworth St
Greenacre NSW 2190
Po Box 194 Nth Strathfield NSW 2137
Tel: (02) 9642 6003 Fax: (02) 9642 6127
Email: general@tortech.com.au
Website: www.tortech.com.au

- If you need to remove a battery, always remove the ground terminal from the battery first. Make sure that all the accessories are off so that you do not cause a spark

3. SPECIFICATIONS

Specs	INV-12-300	INV-12 -600	INV-12 1000
Input Voltage	10.5 to 15.0 VDC	10.5 to 15.0 VDC	10.5 to 15.0 VDC
Output Voltage	240 V AC +/-3%	240 V AC +/-3%	240 V AC +/-3%
Output Frequency	60+/-3Hz	60+/-3Hz	60+/-3Hz
Input Current at No Load	<0.25A	<0.35A	<0.45A
Output Voltage Waveform	Pure Sine Wave	Pure Sine Wave	Pure Sine Wave
Total Harmonic distortion	<3%	<3%	<3%
Output Power Continuous	300W	600W	1000W
Surge(for <1 second)	600W	1200W	2000W
Low Input Voltage Warning	10V to 10.5VDC	10V to 10.5VDC	10V to 10.5VDC
Low Input Voltage Shutdown	9.5V to 10VDC	9.5V to 10VDC	9.5V to 10VDC
High Input Voltage Shutdown	Above 15VDC	Above 15VDC	Above 15VDC
Operating Ambient Temp	32°F to 104°F (0°C-40°C)	32°F to 104°F (0°C-40°C)	32°F to 104°F (0°C-40°C)
Peak Efficiency	>88%	>88%	>88%
Cooling	Temperature Controlled Fan	Temperature Controlled Fan	Temperature Controlled Fan
Input Connection	Cigarette Lighter Plug/Terminal Post	Terminal Post	Terminal Post
Output Connection	North American (NEMA 5-15R)	North American (NEMA 5-15R)	North American (NEMA 5-15R)
DC Side Input Fuse	1PC*35A	2PCS*35A	4PCS*35A
Dimensions(L x W x H) in/mm	6.25X6X2 / 160X150X52	8.25X6X2.75 / 210X150X70	13.25X6X2.75 / 210X150X70
Weight lbs/kg	2.4 / 1.1	4.6 / 2.1	7.7 / 3.5

Note: Specifications are subject to change without notice

4. MAIN COMPONENTS



Edited with the demo version of
Infix Pro PDF Editor

To remove this notice, visit:
www.iceni.com/unlock.htm



Tortech

T/A Tortech Limited Partnership ABN. 31 801 764 359

TORTECH Pty Ltd & TRANSTEST Pty Ltd
4/31 Wentworth St
Greenacre NSW 2190
Po Box 194 Nth Strathfield NSW 2137
Tel: (02) 9642 6003 Fax: (02) 9642 6127
Email: general@tortech.com.au
Website: www.tortech.com.au

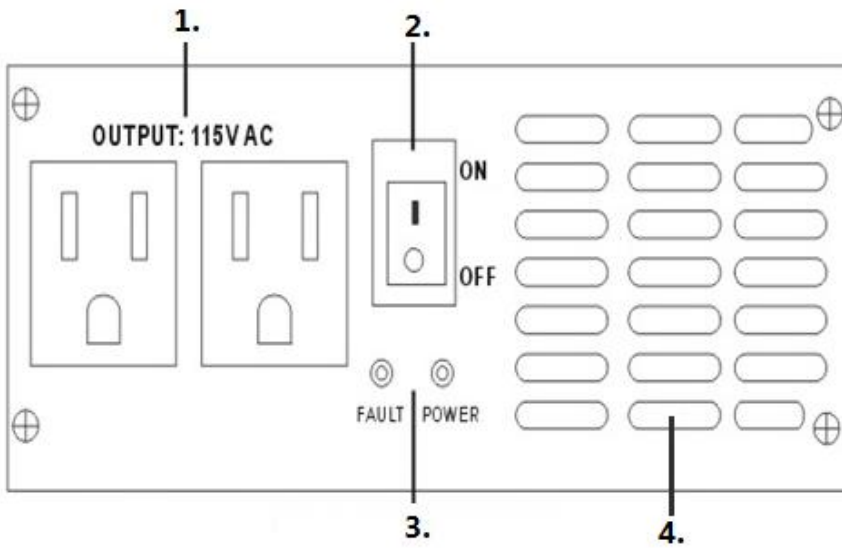

- 1. AC outlet
- 2. ON/OFF switch
- 3. Power Status LEDs
- 4. Vent outlet

Front View

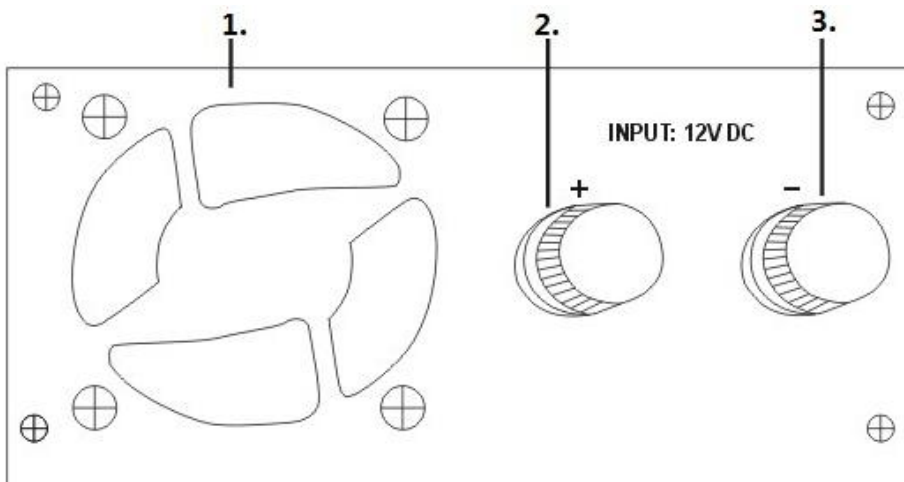

- 1. Cooling Fan
- 2. Positive (Red)
- 3. Negative (Black)

Rear View



Warning: A reverse polarity connection will blow the internal fuse and may damage inverter permanently



5. INSTALLATION

Installation and wiring compliance

- Installation and wiring must comply with the local and the national electrical codes and must be done by a certified electrician
- In building / residential applications, electrical codes do not allow permanent connection of AC distribution wiring to the inverter's AC output receptacles. The receptacles are intended for temporary (as needed) connection of cord connected loads only
- The inverter does not have integral over current protection for the AC output side. Protection should be provided by the installer
- Over current protection of the cables from the battery to the inverter has to be provided by the installer
- The DC input positive and negative terminals are isolated from the chassis. Similarly, the neutral pole of the AC receptacles / the neutral wire is not bonded to the chassis. System grounding to suit the national / local electrical codes is to be undertaken by the installer
- Always connect the grounding connection on the inverter to the appropriate grounding system

Installation environment

- The inverter should be installed indoor only in a well ventilated, cool, dry environment
- Do not expose to moisture, rain, snow or liquids of any type
- To reduce the risk of overheating and fire, do not obstruct the suction and discharge openings of the cooling fan
- To ensure proper ventilation, do not install in a low clearance compartment
- Working with the inverter may produce arcs or sparks. Thus, the inverter should not be used in areas where there are inflammable materials or gases requiring ignition protected equipment. These areas may include spaces containing gasoline powered machinery, fuel tanks, battery compartments

Mounting position of the inverter

- The inverter may be mounted horizontally on the top of a horizontal surface or under a horizontal surface. The inverter may be mounted on a vertical surface only horizontally
- The inverters produce heat when operating. The amount of heat produced is proportional to the amount of power supplied by the inverter. DC fans are used to provide forced air cooling of these inverters. The fans are thermostatically controlled and will be switched on only if the temperature of certain hot spot inside the inverter rises above a certain temperature

DC Input Power

The DC input power to the inverter is derived from deep cycle batteries of the required capacity. The more deeply a battery is discharged on each cycle, the shorter the battery life. It is recommended that the depth of discharge should be limited to 50 %, for more information, please consult the battery manufacture.



TorTech

T/A Tortech Limited Partnership ABN. 31 801 764 359

TORTECH Pty Ltd & TRANSTEST Pty Ltd
4/31 Wentworth St
Greenacre NSW 2190
Po Box 194 Nth Strathfield NSW 2137
Tel: (02) 9642 6003 Fax: (02) 9642 6127
Email: general@tortech.com.au
Website: www.tortech.com.au

DC Input Connection

For connecting the DC input, a pair of 2' DC cable with clip is included (300W, 600W). Please make sure that the red clip goes to the positive terminal of the battery, and the black clip goes to the negative terminal of the battery. Additional cable with a cigarette lighter plug has been provided for 300W inverter, the cable size is AWG #14. 600W and 1000W inverter come with 2 spring washers, when connect the DC cable to the inverter, make sure place the washer on top of cable connector.

Model#	AWG
RP300	10 AWG
RP600	8 AWG
RP1000	6 AWG



Tip: When using cigarette lighter receptacle in a 12V vehicle, limit the power to less than 100 watts as the cigarette lighter receptacle wiring in a 12V vehicle is normally fused for 8Amp to 10Amp

Reducing RF interference

To reduce the effect of radiated interference, twist the DC side cables. To further reduce RF interference, shield the cables with sheathing /copper foil / braiding.

Taping battery cables together to reduce inductance

Do not keep the battery cables far apart. In case it is not convenient to twist the cables, keep them taped together to reduce their inductance. Reduced inductance of the battery cables helps to reduce induced voltages. This reduces ripple in the battery cables and improves performance and efficiency.

AC SIDE CONNECTIONS

The inverter uses NEMA 5-15R receptacle (Standard for North American) for connecting the AC output to devices and appliances fitted with a NEMA 5-15P plug. In this NEMA 5-15R receptacle, two rectangular slots are connected to the current-carrying conductors of the AC power source inside the inverter. The round slot is the "equipment grounding" connection and is internally connected to the metal chassis of the inverter.



CAUTION: For safety, the metal chassis of the inverter is required to be grounded to the earth ground or to the designated ground.

Loads that require "surge power" to start

Resistive types of loads (like incandescent lamps, toaster, coffee maker, electric range, iron etc) do not require extra power to start. Their starting power is the same as their running power. Some loads like induction motors and high inertia motor driven devices will initially require a very large starting or "**surge**" power to start from rest. Once they have started moving and have attained their rated speed, their power requirement reduces to their normal running power. The **surge** may last up to 5 seconds. TVs and microwave ovens also require surge power for starting. The manufacturers' specification of the appliances and devices indicates only the running power required. The surge power required has to be guessed at best. If an inverter cannot efficiently feed the surge power, it may simply shut down instead of starting the device. If the inverter's surge



TorTech

T/A Tortech Limited Partnership ABN. 31 801 764 359

TORTECH Pty Ltd & TRANSTEST Pty Ltd
4/31 Wentworth St
Greenacre NSW 2190
Po Box 194 Nth Strathfield NSW 2137
Tel: (02) 9642 6003 Fax: (02) 9642 6127
Email: general@tortech.com.au
Website: www.tortech.com.au

capacity is marginal, its output voltage will dip during the surge. This can cause a dimming of the lights in the house, and will sometimes crash a computer. Any weakness in the battery and cabling to the inverter will further limit its ability to start a motor. A battery bank that is undersized, in poor condition, or has corroded connections, can be a weak link in the power chain. The inverter cables and the battery interconnect cables must be sized properly. The spike of DC current through these cables is many hundreds of amps at the instant of motor starting.



Tip: The surge power rating specified for this inverter is valid for duration of less than 1 second. This very short duration may not be sufficient to start motor based loads which may require up to 5 seconds to complete starting process. Hence, for purposes of sizing the inverter, use only the continuous power rating of this inverter.

6. OPERATION

After the inverter is switched on, it takes a finite time for it to become ready to deliver full power. Hence, always switch on the load(s) after a few seconds of switching on the inverter. Avoid switching on the inverter with the load already switched on. This may prematurely trigger the overload protection. When a load is switched on, it may require initial higher power surge to start. Hence, if multiple loads are being powered, they should be switched on one by one so that the inverter is not overloaded by the higher starting surge if all the loads are switched on at once.

Switching the inverter on / off

Before switching on the inverter, check that all the AC loads have been switched off. The ON/OFF switch on the front panel of the inverter is used to switch on and switch off the inverter. This switch operates a low power control circuitry which in turn controls all the high power circuitry. When the inverter is switched on, the LED indicator will turn green. This LED indicates that the inverter is operating normally. Under normal operating conditions, AC output voltage will now be available at the output receptacles. Switch on the AC load(s). The green LED should remain lighted for normal operation of the load.

Temperature controlled cooling fan

The cooling fan is thermostatically controlled. Temperature of a critical hot spot inside the inverter is monitored to activate the fan and the over temperature shut-down. When the temperature of this hot spot reaches 113°F (45°C), the fan is switched on. The fan will be automatically switched off once the hot spot cools down to 104°F (40°C).

Please note that the fan may not come on at low loads or if the ambient temperature is cooler. This is normal.

Indications for normal operation

When the inverter is operating normally and supplying AC load(s), the LED will be green. In case of abnormal operation, other displays and alarms will be activated, please refer to the troubleshooting diagnosis table.



7. TROUBLESHOOTING

SYMPTOM	POSSIBLE CAUSE	SOLUTIONS
ON/OFF switch is switched on, LED does not light. Buzzer is off. There is no AC voltage	There is no voltage at the DC input Terminals	<ol style="list-style-type: none"> 1. Check the continuity of the battery input circuit 2. Check that the battery fuse is intact. Replace if blown 3. Check that all connections in the battery input circuit are tight
ON/OFF switch is switched on, LED does not light. Buzzer is off. There is no AC voltage	Polarity of the input voltage has been reversed that has blown the internal fuse	<p>Correct the polarity of the input connections and replace the internal fuse (Note: Reverse polarity may cause permanent damage)</p> <p>If the unit does not work after replacing the fuse, the unit has been permanently damaged, contact manufacturer</p>
Buzzer alarm is sounded once and LED turn RED when ON/OFF switch is switched on	The start surge load is five to seven times of its rated power	Wait in few seconds LED will turn to green, it indicate normal operation. No action is required
Buzzer alarm is sounded every 10 seconds and LED turn RED when ON/OFF switch is switched on	The loads is 120% higher than rated power, the inverter Buzzer will beeps every 10 seconds	<ol style="list-style-type: none"> 1. Disconnect the load 2. Reduce the load
Buzzer alarm is sounded constantly and LED turn RED when ON/OFF switch is switched on	The loads is 400% higher than rated power. Overload shutoff protection switch will cut off the power	<ol style="list-style-type: none"> 1. Turn off inverter 2. Disconnect the load 3. Reduce the load
Buzzer alarm is sounded twice	Voltage at the DC input terminals reads between 10-10.5VDC	<ol style="list-style-type: none"> 1. Check that the battery is fully charged. Recharge, if low 2. Check that the battery cables are thick enough to carry the required current over the required length. Use thicker cables, if required 3. Tighten connections of the battery input circuit
Buzzer alarm is sounded 3 times	Voltage at the DC input terminals reads between 9.5-10VDC	<ol style="list-style-type: none"> 1. Check that the battery is fully charged. Recharge, if low 2. Check that the battery cables are thick enough to carry the required current over the required length. Use thicker cables, if required 3. Tighten connections of the battery input circuit
Buzzer alarm is sounded 4 times	Higher input DC voltage than 15.0VDC	<ol style="list-style-type: none"> 1. Check that the voltage at the DC input terminals is more than 15 VDC 2. Ensure that the maximum charging voltage of the battery charger /alternator / solar charge controller is below 15 VDC 3. Ensure that an un-regulated solar panel or wind turbine is not used to charge a battery
Buzzer alarm is sounded 5 times	System overheating	<ol style="list-style-type: none"> 1. Check that the fan is working. If not, the fan / fan control circuit may be defective, contact manufacturer 2. If the fan is working, check that the ventilation slots on the suction side and the openings on the discharge side of the fan are not obstructed 3. If the fan is working and the



TorTech

T/A TorTech Limited Partnership ABN. 31 801 764 359

TORTECH Pty Ltd & TRANSTEST Pty Ltd
4/31 Wentworth St
Greenacre NSW 2190
Po Box 194 Nth Strathfield NSW 2137
Tel: (02) 9642 6003 Fax: (02) 9642 6127
Email: general@tortech.com.au
Website: www.tortech.com.au

		openings are not obstructed, check that enough cool replacement air is available. Also check that the ambient air temperature is less than 113F ° (45° C) 4. Reduce the load to reduce the heating effect 5. After the cause of overheating is removed and the unit cools down, it will reset automatically
--	--	---

8. MAINTENANCE

The Rite Power inverters are designed for long lasting and required minimum maintenance. To keep your inverter operating properly, you should clean the exterior of the unit periodically. We recommend using a dry cloth to clean the surface to have better thermal radiation, and using the vacuum machine to vacuum the dust and dirt to get better air ventilation. Make sure all the screws are tightly secured.

9. WARRANTY

We warrant this product against defects in materials and workmanship for a period of one year from the date of purchase and will repair or replace any defective Rite Power Inverter when directly returned, postage prepaid, to manufacturer. This warranty will be considered void if the unit has suffered any obvious physical damage or alteration either internally or externally and does not cover damage arising from improper use such as plugging the unit into an unsuitable power sources, attempting to operate products with excessive power consumption requirements, reverse polarity, or use in unsuitable climates.

WARRANTY DOES NOT INCLUDE LABOR, TRAVEL CHARGES, OR ANY OTHER COSTS INCURRED FOR REPAIR, REMOVAL, INSTALLATION, SERVICING, DIAGNOSING OR HANDLING OF EITHER DEFECTIVE PARTS OR REPLACEMENT PARTS. THE WARRANTOR ASSUMES NO LIABILITY FOR INCIDENTAL OR CONSEQUENTIAL DAMAGES OF ANY KIND.